



Conceptual Design Approach of a Hybrid Solar Dryer for Banana Under South Pacific Conditions

Senadeera Wijitha^{1*}, Atojunere Esme Egenoosi¹, Iji Paul¹ and Jimaima Lako²

¹Department of Soil Science and Biosystems Engineering, Fiji National University, Suva, Fiji

²Department of Food Science and Technology, Fiji National University, Suva, Fiji



WebLog Open Access Publications

Article ID : wjacs.2026.e0102
Author : Senadeera Wijitha

Abstract

The idea of developing a solar hybrid banana dryer designed explicitly for South Pacific will be a significant step forward in addressing both environmental sustainability and economic efficiency in the region. This paper encompasses the design steps and calculations of a sophisticated drying system tailored to meet local conditions, assuming one hybrid dryer as an example. It features an array of components such as solar panels, batteries, solar collectors, an air filter, a heat exchanger, a drying chamber, electric heaters, forced ventilation, and a control unit. This paper details the various phases of the project, including design objectives, options, literature review findings, design selection processes, detailed design calculations, and forward-looking recommendations. This design procedure can serve as a guide and can be used by any person who is interested in designing a dryer to meet South Pacific economic and environmental needs. The primary aim was to create a low-cost, sustainable, portable dryer that is simple to construct and maintain and capable of upholding hygiene standards despite variable weather conditions. When designing the dryer all calculations were presented as a guide for anyone and banana was used as the model material to produce banana powder, but it can be used for crops like breadfruit, pineapple, tomatoes and cassava and whatever else can benefit. By adopting this innovative solution, south pacific can benefit from an environmentally friendly, economically viable method of banana drying, supporting local agriculture and contributing to sustainable development in the region.

OPEN ACCESS

*Correspondence:

Senadeera Wijitha, Department of Soil Science and Biosystems Engineering, Fiji National University, Suva, Fiji, Tel: +61 412956461;

E-mail: wijitha.senadeera@fnu.ac.fj

Received Date: 09 Apr 2026

Accepted Date: 29 Apr 2026

Published Date: 01 May 2026

Citation:

Wijitha S, Esme Egenoosi A, Paul I, Lako J. Conceptual Design Approach of a Hybrid Solar Dryer for Banana Under South Pacific Conditions.

WebLog J Agric Crop Sci. wjacs.2026.e0102. <https://doi.org/10.5281/zenodo.20003110>

Copyright© 2026 Senadeera

Wijitha. This is an open access article distributed under the Creative Commons Attribution License, which permits unrestricted use, distribution, and reproduction in any medium, provided the original work is properly cited.

Keywords: Design Steps; Solar Dryer; Calculations; South Pacific Conditions

Introduction

In south pacific the main nation in economical and our focus is on the tropical paradise of Fiji, where bananas thrive in abundance, local farmers often need help to keep surplus produce unless leading to significant wastage. To address this issue, the paper addresses basic calculation steps in designing a solar-powered banana dryer tailored to Fijian conditions. Our goal is to empower farmers by providing a solution that reduces product wastage and offers a secondary source of food and income for their families and the broader community. Converting unsold bananas into banana powder, which boasts an extended shelf life, can transform what would have been wasted into a valuable commodity. To address this, we propose a promising solution: transforming these surplus bananas into powder with an extended shelf life. This work outlines the comprehensive design process of our batch-drying system, highlighting the importance of meticulous planning and effective risk management. We explore various design options, evaluate their feasibility and suitability for the local context, and only present a well-considered recommendation to guide stakeholders in making informed decisions.

This initiative aims to leverage solar-powered drying technology, capitalizing on Fiji's abundant sunshine to efficiently and sustainably process bananas. Solar-powered dryers are a fitting solution for the region's climatic conditions, as they offer an eco-friendly method to remove moisture from bananas, thereby preserving their nutritional value and preventing spoilage. By implementing effective drying techniques, it not only seeks to create new income streams for farmers but also plays a crucial role in ensuring food security. The production of banana powder facilitates market expansion and introduces opportunities for value-added products, thus encouraging entrepreneurship within local communities. The gross salary ranges for individuals employed in Fiji's agriculture and food industry is generally between 994 FJD and 2,510 FJD per month given by several publications [1, 2], highlighting the need for cost-effective and efficient solutions. Developing a solar banana drying device could increase the shelf life and quality of bananas and other crops such as breadfruit,

pineapple, shrimps, cassava etc., thereby providing better market opportunities and increasing the income levels of those involved in the crop supply chain reported by several researchers [3-6].

Fiji's climate features relatively consistent temperature ranges throughout the year, with average temperatures during the dry season (May to October) ranging between 18°C and 28°C and slightly higher temperatures during the wet season (November to April), averaging between 21°C and 30°C. Regarding precipitation, Fiji experiences more pronounced seasonal variation: the wet season is marked by substantial rainfall, averaging between 250 and 400 mm monthly, while the dry season typically sees only 80 to 150mm of monthly rainfall reported by climate publication of Fiji [7]. This variation in rainfall can significantly impact a solar-powered banana drying system as cloud covers and rain can affect drying times and solar availability for the region. Despite the variations in Fiji's climate, the country boasts a significant solar energy potential. On average, Fiji enjoys a high annual solar insolation of 5.4 kWh/m²/day on a horizontal basis Prasad *et al.*, [8]. This level of solar insolation, which remains remarkably consistent from 9 a.m. to 3 p.m., positions Fiji as an excellent location for implementing solar-powered technologies like the banana drying system and 92.1% of population has electricity [9, 10].

Ripe bananas, with a moisture content of approximately 75%, require effective drying methods to transform into banana chips Amankwah *et al.*, [11]. The moisture content of banana slices increases with slice thickness, significantly impacting the drying process. Trials on banana slice thickness have revealed that mold was present in 38% of the batches when the slices were 6mm or thicker, while no mold was found on slices between 1 mm and 4 mm thick reported by Kunwisawa *et al.*, [12]. Therefore, managing the thickness of the banana slices is crucial to prevent spoilage and ensure quality in the drying process.

This thick range prevents mold growth and balances the drying time and energy efficiency. During testing, banana slices with a thickness of 4-5mm and a batch mass of 3.18kg required 16 hours to dry, based on 8 hours of drying per day reported by Mawire *et al.*, [13]. This suggests that even slight variations in slice thickness can affect the total drying time, making it essential to adhere closely to the recommended thickness.

Furthermore, drying times can vary depending on airflow velocity. With an average airflow velocity of 0.11m/s to 0.23m/s, drying times can extend up to 24 hours [13]. This prolonged drying time underscores the necessity for efficient airflow management in the solar drying process to optimize the drying period and uphold the quality of the banana chips. Solar-powered banana chip dryers can achieve efficient and high-quality drying results by meticulously controlling slice thickness and airflow. Solar dryers are innovative devices that utilize solar energy to remove moisture from various materials, typically agricultural products. These dryers can be classified based on different criteria. The first classification is by the mode of heat transfer. In open sun drying, products are spread out under direct sunlight, which is the simplest and most traditional method (Figure 1). Direct solar dryers involve a more structured system, here the products are enclosed in a chamber with transparent materials, allowing sunlight to heat them directly (Figure 2). On the other hand, indirect solar dryers separate the heat collection and drying processes, using a solar collector to heat air through the drying chamber (Figure 3). Hybrid solar dryers, however, stand out for their

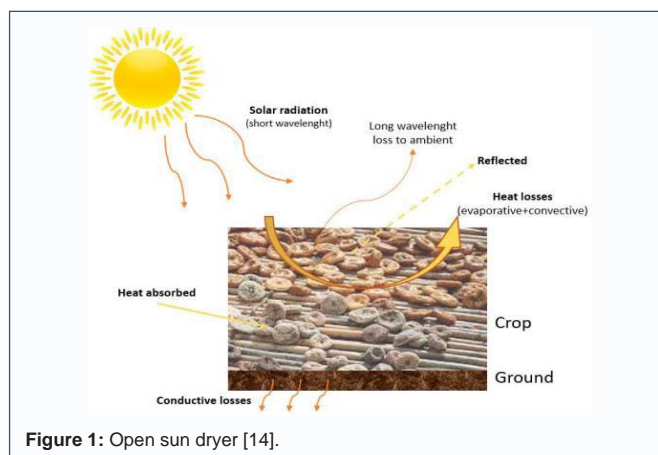

Figure 1: Open sun dryer [14].

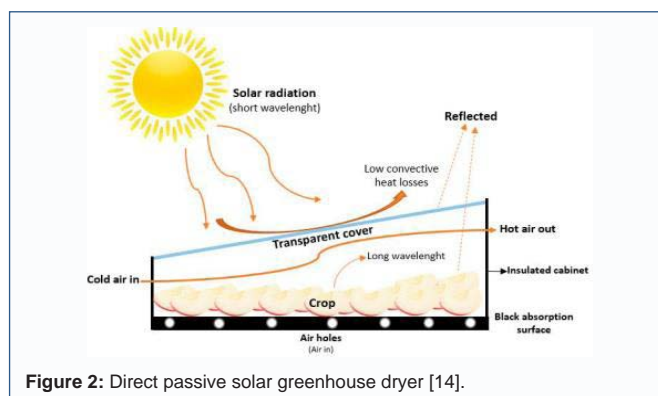

Figure 2: Direct passive solar greenhouse dryer [14].

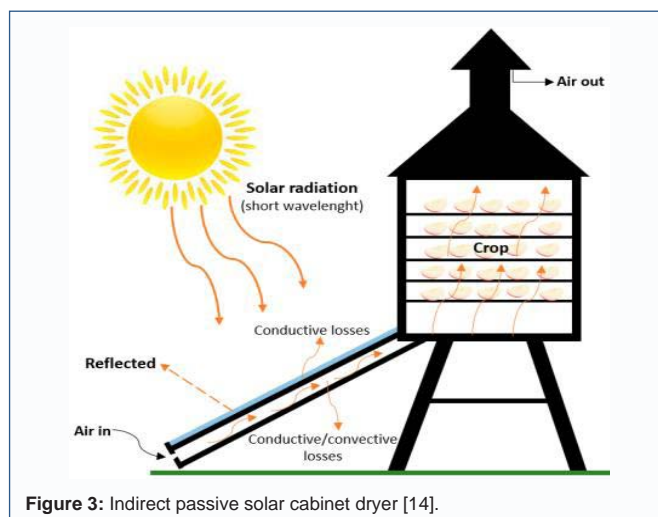
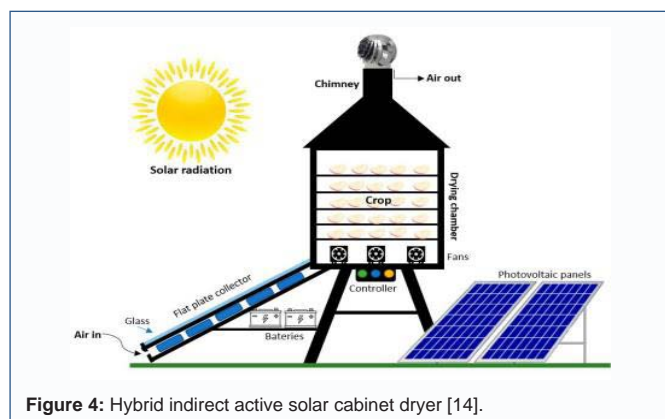

Figure 3: Indirect passive solar cabinet dryer [14].

adaptability. They combine solar energy with other sources, such as electricity or biomass, to ensure consistent drying even when solar radiation is insufficient, providing a reliable solution for all drying conditions (Figure 4).

To ensure adequate airflow, a hybrid solar dryer combines solar radiation with electrical energy or stored heat and either passive or active ventilation (electric fans). According to Fernandes *et al.*, [14] "The primary purpose of a hybrid dryer is to overcome the limitations of other types of solar dryers and improve the overall dryer efficiency." Constructing efficient and sustainable infrastructure in resource-constrained settings is crucial like remote Fiji and insulation



and fire-proofing measures to ensure the banana dryer's safety and effectiveness and Combination of material and finish ensures functional and aesthetic performance, making it an ideal choice for coastal applications [15-17]. In some remote areas, floating produce to market on bamboo rafts downriver is still utilized to transport the produce reported by Foster *et al.*, [18]. This diverse transportation network must be considered when deploying solar-powered banana dryers, as the ease of access to markets can significantly impact the profitability and sustainability of such initiatives.

Developing a conceptual design procedure for a solar assisted hybrid dryer system is scarce only few publications available for South Pacific region. Solar food dryer is an emerging technology in the region [5, 19]. In the past, Pacific farmers relied on traditional sun drying of incline wooden platform to dry foods products which exposed dried products to many risks. Moreso, imported solar dryer are electric powered which is gold in the region. Therefore, developing a hybrid solar dryer is a novel climate smart technology serving dual purposes, (1) to combat food losses and (2) to reduce the effect of climate change region. Using correct procedural calculations and matching of components incorporating new technologies is a significant step towards to make systems more efficient and user friendly. This is an attempt to provide correct procedure for a solar assisted solar drying system design. This hybrid solar dryer would incorporate a multi-energy system combining solar energy and wet cell battery to provide all round the clock drying of bananas. Consequently, it will significantly improve the drying efficiency, enhance product quality and reliability. The hybrid dryer would further incorporate Internet of Things (IoT) based smart control systems enabling real-time monitoring and automation of the drying conditions of bananas through installation of sensors to track temperature, humidity, moisture content automatically. This paper guides the reader on what basic steps need to be taken to design or select a solar drying system or hybrid system for any crop for further processing from the initiation and helps novices to understand what steps and calculations they need to perform for a project of this nature.

Methodology

Objectives

The design process began with establishing clear objectives to guide the development of a banana dryer that could effectively operate within Fiji's unique conditions. A thorough literature review identified a wide range of existing designs and technologies, providing a foundation for building our customized solution. From this research, four design options were shortlisted for further

evaluation (not included). Preliminary calculations were conducted on these options, which were then assessed and ranked against the design objectives using a weighted scoring system. This rigorous process ensured the selection of a final design that best met all criteria.

Opting for a batch of 50 kgs of bananas is not just a cost-effective choice but also a highly efficient one. This quantity, which fits into 11 trays and includes approximately 88 bananas, yields about 8.3kgs of banana powder. This practical and effective output can be used for culinary or commercial purposes, making it a financially sound investment.

Banana dryer is not just a one-size-fits-all solution. Its scalable design during manufacturing allows us to produce larger dryers as per the demand. This flexibility is achieved by incorporating additional batteries, solar panels, and dehumidifiers, which adjust the dryers' functionality and capacity. This adaptability ensures that the dryers can efficiently respond to increased capacity requirements and technological advancements, making them a future-proof investment. Banana dryer has been designed with simplicity in mind, ensuring it is easy to maintain and repair. Its straightforward design reduces the system's complexity, enabling farmers to perform all necessary maintenance tasks efficiently. This user-friendly approach simplifies upkeep and minimizes the risk of component failure during transportation. By addressing these factors, the dryer provides a reliable and efficient solution for drying bananas, allowing farmers to focus on their core 10 activities without worrying about intricate technical issues. This design instils confidence in the dryers' ease of use and maintenance.

Sustainable and environmentally friendly practices are crucial for preserving our planet's resources and ensuring a healthier future for all. By adopting sustainable methods, we minimize waste, reduce pollution, and conserve natural resources, all of which contribute to a more balanced ecosystem. Environmentally friendly approaches, such as using renewable energy sources, reducing single-use plastics, and promoting biodiversity, help mitigate climate change and protect wildlife habitats. These efforts support the environment, foster economic growth, and enhance the quality of life for communities worldwide. The integration of solar and electrical heating has resulted in a more robust and sustainable design, capable of optimizing the drying process and maintaining consistent quality.

The choice of materials further supports the system's longevity and performance. Stainless steel 316 can be selected over aluminum for its durability, making a key factor for ideal for the harsh environment. Polycarbonate over glass as well as lightweight insulation materials improve properties, temperature fluctuations and impacts enhancing overall durability of the system.

Assumptions

Fiji, an island nation with over 300 islands, requires efficient solutions for transporting equipment across its diverse geography. The dryers' portable and modular design addresses this need by ensuring they can be easily transported using various methods, whether by boat, plane, or vehicle. This flexibility in transportation facilitates the movement of dryers between islands and ensures they can be quickly and efficiently deployed wherever needed, supporting South Pacific's unique logical challenges.

In designing structures in Fiji, it is crucial to utilise materials that are tolerant to weather conditions, given the island's unique climate challenges. With its hot and humid environment and exposure to sea

spray, materials must be selected for their resilience. Additionally, the island experiences significant monthly rainfall ranging from 80 to 400mm [7]. Therefore, incorporating materials that can withstand such climatic extremes will ensure the durability and longevity of the structures.

Marketing strategy

The cost of a dryer, ranging from \$4,500 to \$7,000 as per the Bill of Quantities (BoQ) (not presented in the manuscript), is strategically set to remain affordable, enabling more farmers to purchase or be provided with this essential equipment. By keeping the cost low, accessibility is significantly increased, allowing more farmers to benefit. This, in turn, facilitates the farmers' ability to establish a second income stream more efficiently, enhancing their financial stability and overall economic resilience. This affordability positively impacts farmers' financial stability, fostering optimism about the project's outcomes.

Beginning with an initial build of five units, allowing us to gauge the feasibility without committing substantial funds upfront. This approach enables us to assess the success of the dryers across different regions of Fiji. By strategically distributing these initial units, we can evaluate their performance in various areas and determine the project's viability before scaling up production.

Operations

After the concept for the solar hybrid banana dryer is completed, it is recommended that initial unit be manufactured. This prototype will undergo thorough testing and commissioning to ensure functionality and reliability. A strategic advertising and training campaign will be launched to promote the product across Fiji. Feedback and data gathered from this initial deployment will be critical in refining the design, addressing any issues, and optimizing the dryer for a broader market launch. This phased approach enhances the product's success and ensures alignment with the community's needs and expectations.

The design will use off-the-shelf components where practical to allow for reduced manufacturing costs and future replacement or upgrades. Our design will allow for a batch of 10kg of fresh bananas to be dried and milled into 1.6kg a day even during partially cloudy weather or short-day-time rain events (dependent on desired temperature), the system may not be able to continue during prolonged consecutive days of low sunlight.

By adopting this innovative solution, Fiji can benefit from an environmentally friendly, economically viable method of banana drying, supporting local agriculture and contributing to sustainable development in the region. The movement of dryers between islands and ensures they can be quickly and efficiently deployed wherever needed, supporting Fiji's unique logistical challenges.

Use of suitable materials will extend longevity and resistance to harsh environments, reducing maintenance requirements. The cost of the dryer, ranging from F\$4,500 to F\$7000 as per Bill of Quantities (BOQ), is strategically set to remain affordable, enabling farmers to purchase.

Design

Conceptual design

Based on the objective, constraints and assumptions outlined designed a system to capture energy from the sun via a solar thermal panel used to directly heat air and a solar PE panel array to charge a

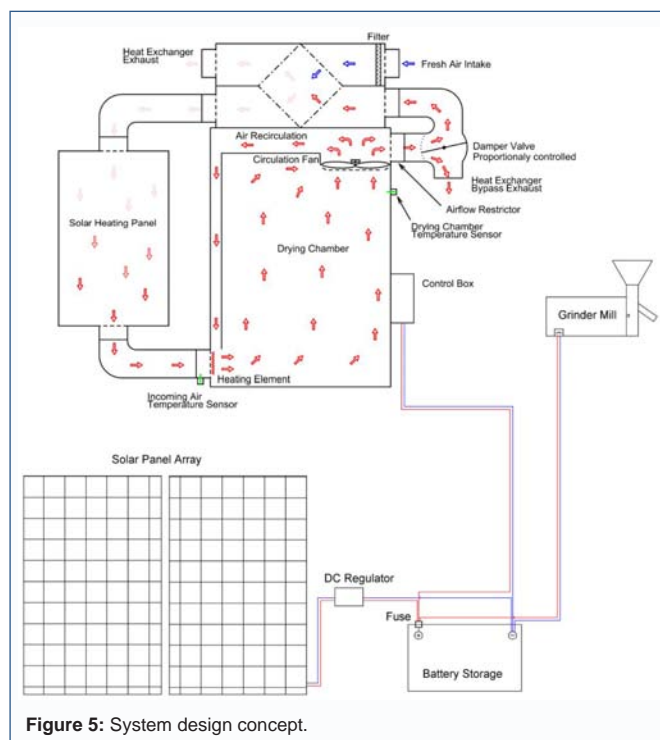

Figure 5: System design concept.

battery storage system. This energy will be used to heat and circulate air through our drying chamber. The system will be able to recapture the heat from the exhausted air via a heat exchanger but could bypass the heat exchange using a proportionally controlled damper actuator to prevent the system overheating as seen in Figure 5. The airflow exhausted out of the system will be manually adjustable by changing the air flow restrictor and calibrated using an airflow sensor, once set this should not need to be changed, unless the system altering airflow characteristics.

Novelty, objectives and expected contributions of the manuscript

The system will be able to recapture the heat from exhaust air via a heat exchanger. This hybrid solar dryer would incorporate a multi-energy system combining solar energy and wet cell battery to provide all round the clock drying of bananas. Consequently, it will significantly improve the drying efficiency, enhance product quality and reliability.

The hybrid dryer would further incorporate Internet of Things (IoT) based smart control systems enabling real-time monitoring and automation of the drying conditions of bananas through installation of sensors to track temperature, humidity, moisture content automatically.

The procedure guides any designer to develop a suitable system of hybrid solar dryer. Also 3-D drawings could be scalable to any capacity and change CAD drawings to manufacture the dryers.

Design calculations

A series of design calculations have been developed for our chosen design option. These calculations are based on information gathered during the literature review, assumptions objectives and constraints outlined. Some values used in the calculations have been estimated based on available data or the expectation that they will not greatly impact the final required values.

(1). Solar collector irradiation calculation results

Suva latitude=18.1405°

Suva longitude=178.423°

Calculations are based on May 20 at 0900 hrs, then $\Phi = -18^\circ$ Irradiance measured on a horizontal plane= $G_h = 1.0 \text{ MJ/hm}^2$ Declination $\delta = 19.93^\circ$ Hour angle = -45° Angle between the beam radiation and the vertical, $\theta_z = 58.2^\circ$

Assuming the diffusion component is insignificant compared to the beam component,

Beam component of irradiance $G' = 1.90 \text{ MJ/hm}^2$ Slope of the solar collector = 30° Azimuth facing due North = $-\gamma = 180^\circ$ Angle between the beam and the collector = $\theta = 43.9^\circ$

Irradiance on the collector (neglecting diffuse radiation) = $G_c = 1.36 \text{ MJ/hm}^2$

Value of diffuse radiation (same in all directions) so $G_{dh} = G_d' = G_{dc} = 0.5 \text{ MJ/hm}^2$

Beam component = $G_b' = 0.9490 \text{ MJ/hm}^2$ Total irradiation in the beam direction = $G_t' = 1.445 \text{ MJ/hm}^2$ Total irradiation on the collector = $G_c' = 1.18 \text{ MJ/hm}^2$

(2). Dryer design calculations

Initial moisture content 75% (wb)

Final moisture content 8% (wb)

Batch size (initial weight of banana slices) = 50kg

Batch size (dried chips) $\sim 50/6 = 8.3\text{kg}$

Slice thickness (before drying) = 0.4cm

Tray size = 80cm x 80cm

Bananas per tray = 8

Banana weight (pulp) = 114.54 grams

Number of bananas per batch = 10,000 grams / 114.54 grams / banana = 86 bananas

Number of trays required = 86 / 8 = 11 trays.

(3). Moisture calculations

Design Calculations (from Murali *et al.*,) [3]:

The amount of moisture to be removed from the banana slices is:

$$M_w = (M_i - M_f) / (100 - M_f) * m$$

$$M_w = (75 - 8) / (100 - 8) * 50 = 36.41\text{kg}$$

Where:

 M_w = Total amount of moisture to be removed (kg) M_i = Initial moisture content = 75% M_f = Final moisture content = 8% m = Weight of banana slices for one batch = 50kg

(4). Energy requirements

The heat energy required is:

$$Q_t = M_w L_h$$

$$Q_t = 36.41 * 2,260 = 82,286.6\text{kJ}$$

Where:

 Q_t = Total amount of heat required (kJ) M_w = Total amount of moisture to be removed (kg) = 36.41 L_h = Latent heat of vaporisation of water (kJ/kg) = 2,260

Theoretical specific energy requirement = 82,286 / 50 = 1645 kJ/kg

(5). Drying air requirements

Drying air flow rate is:

$$M_a = Q_t / C_p * (T_{di} - T_{do})$$

$$M_a = 82,286.6 / (1.005 * (343.15 - 298.15)) = 1,819.49\text{kg}$$

Where:

 M_a = Mass of air required (kg) Q_t = Total amount of heat required (kJ) = 82,286.6kJ C_p = Specific heat of air (kJ/kg-K) = 1.005 T_{di} = Inlet air temperature (K) = 298.15 (25°C) T_{do} = Outlet air temperature (K) = 343.15 (70°C)

Total volume of air required for the process is:

$$V_a = (m_a * R * T) / P$$

$$V_a = (1,819.49 * 0.287 * 343.15) / 1.016 = 176,368.84\text{m}^3$$

Where:

 V_a = Total volume of air required (m³) m_a = Mass of air required (kg) = 1,819.49 R = Gas constant (kPa.m³/kg/K) = 0.287 T = Temperature (K) = 343.15 P = Pressure (kPa) = 1.016

Volumetric air flow rate required is:

$$V_{ra} = V_a / Dt = 176,368.84 / 10 = 17,636.88\text{m}^3/\text{h}$$

Where:

 V_{ra} = Volumetric air flow rate (m³/h) V_a = Volume of air required (m³) = 176,368.84 Dt = Drying time (h) = 10

Mass flow rate of air required is:

$$M_{ra} = V_{ra} * \rho = 17,636.88 * 1.2 = 21,164.26\text{kg/h}$$

Where:

 M_{ra} = Mass flow rate of air (kg/h) V_{ra} = Volumetric air flow rate (m³/h) = 17,636.88 ρ = Density of air (kg/m³) = 1.2

(6). Solar collector surface area required:

$$Ac = Qt / (I * Dt) = 82,286.6 / (1,361 * 10) = 6.05 m^2$$

Where:

Ac = Area of solar water collector (m^2)

Qt = Total amount of heat required (kJ) = 82,286.6 kJ

I = Average incident solar radiation (W/m^2) = 1,361 W/m^2

Dt = Drying time (h) = 10

(7). Heat exchanger area required:

$$LMDT = F * ((Thi - Tdo) - (Tdo - Tdi)) / (\ln(((Thi - Tdo)) / ((Tho - Tdi))))$$

$$LMDT = 0.92 * ((363.15 - 343.15) - (353.15 - 298.15)) / (\ln(((363.15 - 343.15)) / ((353.15 - 298.15))))$$

$$LMDT = 31.83$$

$$Qh = U * Ah * LMDT$$

Where:

Qh = Heat transfer per hour (kJ/h)

U = Overall heat transfer coefficient (kJ/h.m².K)

Ah = Area of heat exchanger (m^2)

$LMTD$ = Log Mean Temperature Difference

F = Correction factor for heat exchanger = 0.92

Tdi = Inlet air temperature (K) = 298.15 (25°C)

Tdo = Outlet air temperature (K) = 343.15 (70°C)

Thi = Heat exchanger water inlet temperature (K) = 363.15 (90°C)

Tho = Heat exchanger water outlet temperature (K) = 353.15 (80°C)

Heat exchanger water flow rate required is:

$$mrw = Qh / (Cpw * (Thi - Tho))$$

Where:

mrw = Mass flow rate of water (kg/h)

Qh = Heat transfer per hour (kJ/h)

Cpw = Specific heat of water (kJ/kg.K) = 4.187

Thi = Heat exchanger water inlet temperature (K) = 363.15 (90°C)

Tho = Heat exchanger water outlet temperature (K) = 353.15 (80°C)

(7). Drying chamber size:

To accommodate 112 stainless steel perforated trays (80cmx80cm) the drying chamber consists

of four columns of 28 trays. Overall dimensions are 2m wide, 2m deep, and 1.8m high.

LPG hot water system:

A 15L hot water system (commonly used in caravans) with a 13kg LPG bottle (common size that is

available in Fiji) was chosen for this project.

(8). Design calculations for banana requirements

Banana pulp size:

$Diameter(D) = 4cm$ Length of Banana (LB) = 20cm Slice Thickness (h) = 0.4cm

Banana slice surface area:

$$A = 2\pi rh + 2\pi r^2 = 2\pi * (4 cm^2) * 0.4 cm + 2\pi * (4 cm^2)^2 = 25.64 cm^2$$

Slices per banana pulp

$$Slices \text{ per banana } (Ns) = LBT = 20 cm / 0.4 cm = 50 \text{ slices}$$

Banana drying tray area:

$$Lenght (L) = 80 cm \text{ Width } (W) = 80 cm$$

$$Atray = L * W = 80 cm * 80 cm = 6400 cm^2$$

Number of slices per tray:

$$n = Atray / A = (80 cm^2 / 25.64 cm^2) = 202 = 400 \text{ slices}$$

Bananas per tray:

$$N_{banana} = n * Ns = 400 * 50 = 8 \text{ bananas}$$

How many bananas to make 1kg of Powder:

Based on research it is assumed it takes 6 kg of bananas to produce 1kg of banana powder.

$$\text{Weight of Banana } (WB) = 111.54g$$

$$6000g / WB = 6000g / 111.54g = 51 \text{ bananas}; 51 \text{ bananas} / 8 \text{ bananas} = 7 \text{ tray per } 8.6 \text{ kg of powder}$$

Therefore, it takes 51 bananas placed on 7 trays to produce 1kg of banana powder.

(9). Air flow and power calculations

The system is expected to exhaust around 1 cubic meter of air every minute (60 m³/hr), as the system will be heating the air it will not need to draw the same amount of fresh air in. The volume of air that needs to be brought into the system every hour (FAV) can be calculated by using the Exhaust temperature (Et) the Ambient temperature (At) and the Exhaust volume (Ev). We have excluded the volume change caused by the change in humidity of the air in these calculations.

$$Ev * At / Et = FAV \text{ m}^3/\text{hr}$$

The temperature of the incoming air after it passes through the Heat exchanger (It) can be calculated by using the Exhaust temperature (Et) the Ambient temperature (At) and the Heat Exchanger efficiency

$$(HEe). At + (Et - At) HEe = It$$

From the literature review conducted it has been determined that cross flow Heat exchangers can have an efficiency of up to 80%, we will be aiming for a heat exchange that allows up to achieve around maximum efficiency, so calculations will be based on a HEe of 75%.

If the system temperature is set at 65°C and the ambient temperature in 20°C with a heat exchanger efficiency of 75% then from the formula above the incoming air temperature will be 54°C and need to be heated a further 11°C.

Using a rough guide, it takes 1kW to raise 1kg (Calculated as 1kg = 1m³ of air at 20°C) of air difference of 1°C in one second. Fresh air Volume: 60 * 2065 = 18.5 m³/hr

Given that we need to heat 18.5 m³ of air every hour we can determine the energy required to raise the air to the required

temperature both with the heat exchanger and without. Using the formula below we can work out the instantaneous power required.

$$\text{With HE raise } 11^{\circ}\text{C: } W/\text{hr} * \text{temp } 3600 \text{ Sec} = W = 18500 * 113600 = 57W$$

$$\text{Without HE raise } 45^{\circ}\text{C: } W/\text{hr} * \text{temp } 3600 \text{ Sec} = W = 18500 * 453600 = 231W$$

For the electric heating element, we convert this to amps.

$$\text{Watts/Volts} = \text{Amps} = 57/12 = 4.75A$$

(10). Solar thermal panel

For the Solar thermal panel, we need to look at the solar radiance and efficiency to work out the minimum required surface area of the panel as well as the maximum size that the system can handle without causing the system to overheat.

Min Power 57W+losses

Max power 231W+losses

The Panel could be designed with a power greater than the maximum stated above to allow the system to be more effective on low sunlight days, but the system operator would need to cover part of the panel on full sunlight days when the system is set to lower temperatures to prevent overheating.

(11). Electrical component power allowances

We have calculated the Battery Storage that is required to run the system outside of sunlight hour by using the electrical component power requirements (Wattage) and the time it will be used for outside of sunlight hours per batch with the formula below. We have aimed for a batch time of 10 hours and allowed 6 hours of sun on an average day leaving a 4-hour period to be powered off the battery.

$$Ah = \text{Watts/Volts} * \text{Minutes used } 60 \text{ (or Time used in Hours)}$$

Grinder Mill:

From the literature review conducted it has been found that off the shelf grinder mill options that are around 300W can grind around 100-150 g per minute, given that the batch size will be around 1.6kg it will take around 15 mins to process the batch. From the calculations below we can determine that we will need to reserve 7Ah of the battery for this purpose.

$$Ah = \text{Watts/Volts} * \text{Minutes used } 60 = 300/12 * 15/60 = 6.25Ah$$

Fan:

The design will use a 70w fan to circulate and exhaust air, which will run constantly while the system is on.

$$Ah = \text{Watts/Volts} * \text{hours} = 50/12 * 4 = 17Ah$$

Heating element:

From calculations above the heating element will need to be 57W but will allow for a 75W element to allow for heat loss out of the system.

$$Ah = \text{Watts/Volts} * \text{hours} = 75/12 * 4 = 25Ah$$

Electronic control system:

We will allow 0.5 Amps for the electronic control system including the damper actuator $0.5A * 4h = 2Ah$

Total storage required on an average day is 51Ah

(12). Low sunlight days

For days with less sunlight, we would like the system to still be able operate and complete a batch using the limited sun it gets and the leftover storage for the previous day.

Redoing the above calculations based on a batch being completed solar off the battery storage gives a need for 116Ah, this does not consider the energy requirement to initially get the system up to temperature.

$$\text{Grinder: } 300/12 * 15/60 = 6.25Ah$$

$$\text{Fan: } 50/12 * 10 = 42Ah \text{ Heating element: } 75/12 * 10 = 62.5Ah$$

$$\text{Electronic control system: } 0.5A * 10h = 5Ah$$

(13). Battery and solar PE panel sizing

Allowing for 10% efficiency loss and a battery degradation or around 25% over its lifespan we have calculated 172Ah of battery storage is required.

Solar PE panel sizing will be based on replenishing the required battery storage in one day whilst the fan and control system are running. Required power in kW/h will be 2.4kWh given a solar radiance of 5.4 kWh/m²/day a panel efficiency of 20% degraded to 18% over the life of the panel (degraded 1%/year for 10 years), the solar panel area will need to be 2.4 m².

$$\text{Battery Storage} = 16/0.75/0.9 = 172Ah$$

$$\text{Fan } 50/12 * 6 = 25Ah \text{ Electronic control system: } 0.5A * 6h = 3Ah$$

$$\text{Required power } (172 + 25 + 3) * 12 = 2.4kW/h$$

$$\text{Panel area} = 2.4 * 5.4 * 0.18 = 2.4m^2$$

$$\text{or Panel rating for 6 hours full sun } 2400W/h * 6h * 85\% = 470W$$

(14). Tray size and production capacity

The calculations of the tray size enable us to determine how many trays are required to perform a 1kg and 10kg batch. By understanding tray requirements, we can determine how many bananas are required based on the given data below.

Banana Pulp:

$$\text{Diameter (D)} = 4cm$$

$$\text{Length of Banana (LB)} = 20cm$$

$$\text{Area occupied by one slice (As)} = 80 \text{ cm}^2$$

$$\text{Slice Thickness (h)} = 0.4cm$$

$$\text{Surface Area } A = 2\pi rh + 2\pi r^2 = 2\pi(4cm) * 0.4cm + 2\pi * (4cm)^2 = 25.64 \text{ cm}^2$$

$$\text{Slices per banana pulp: slices per banana (Ns)} = LB/h = 20cm/0.4cm \sim 50 \text{ slices}$$

Banana drying tray area:

$$\text{Length (L)} = 80 \text{ cm}$$

$$\text{Width (W)} = 80 \text{ cm}$$

$$\text{Area Tray} = L * W = 80 \text{ cm} * 80 \text{ cm} = 6400 \text{ cm}^2$$

$$\text{Number of slices per tray: } n = \text{Area tray} / A_s = (6400 \text{ cm}^2 / 16 \text{ cm}^2) = 400 \text{ slices}$$

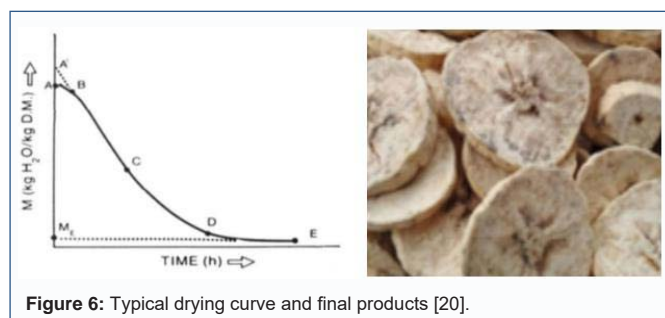

Figure 6: Typical drying curve and final products [20].

Bananas per tray: $N_{\text{Banana}} = N/N_s = 400/50 = 8$ bananas

(15). How many bananas to make 1.6kg of Powder

Based on research it is assumed it takes 10 kg of bananas to produce 1.6kg of banana powder.

Weight of Banana (WB)=111.54g

$10000gWB = 10000g/111.54g = 86$ bananas per 1.6kg of powder

$86 \text{ bananas} / 8 \text{ bananas} \sim 11$ trays per 8.3kg of powder

Therefore, it takes 51 bananas placed on 11 trays to produce 8.3kg of banana powder.

(16). Typical drying curve of dehydrating process and dried banana

Figure 6 displays typical drying curve of banana in a typical dehydrating system and final dried products. The curve begins with the initial moisture reading of 75% present in the raw banana slices and concludes as a finished product with a moisture reading of 8%. From A-B is the initial adjustment period. This segment expresses the change the banana undergoes from its ambient temperature and moisture content to the start of the drying process. Normally this period increases the moisture present within the product though increases its internal temperature. As the heat will draw surrounding moisture present in the dehydrating chamber into the fruit. B-C expresses the major change that the fruit slices would undergo and removes a large majority of the banana's water content in a short period of time at a constant rate. C-D extends this period especially for foods with a very high moisture content. Though this section removes the moisture at a slower rate than B-C. Period D-E is utilized to take the banana chips from a pliable structure to its final moisture content of optimally 8% compared to its original moisture content of 75%.

Design modelling & drawings

The modelling and detailed drawings in this section of the report have been constructed using computer-aided drawing software. Design adopts similarities from proven technologies; however, several enhancements have been included to better align with the design objectives. These enhancements ensure that the solar hybrid banana dryer not only meets but exceeds current industry standards.

The integration of solar and electrical heating has resulted in a more robust and sustainable design, capable of optimizing the drying process and maintaining consistent quality. This approach not only optimizes performance but also extends the lifespan of the dryer, providing a more cost-effective and reliable solution for banana drying in the long run. It's important to note that the modelling and drawings for the design are purely conceptual with the intent to

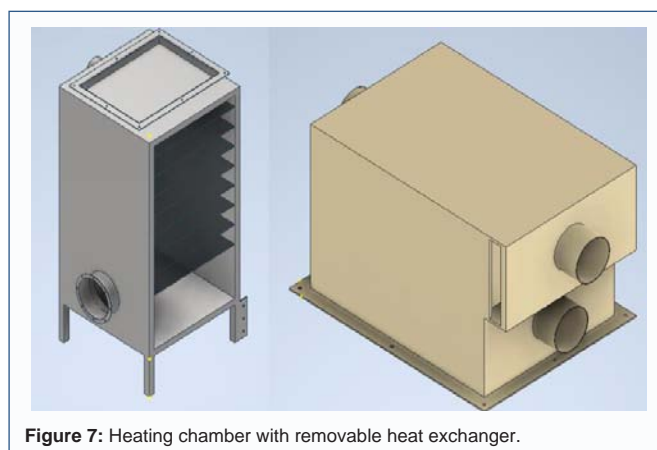

Figure 7: Heating chamber with removable heat exchanger.

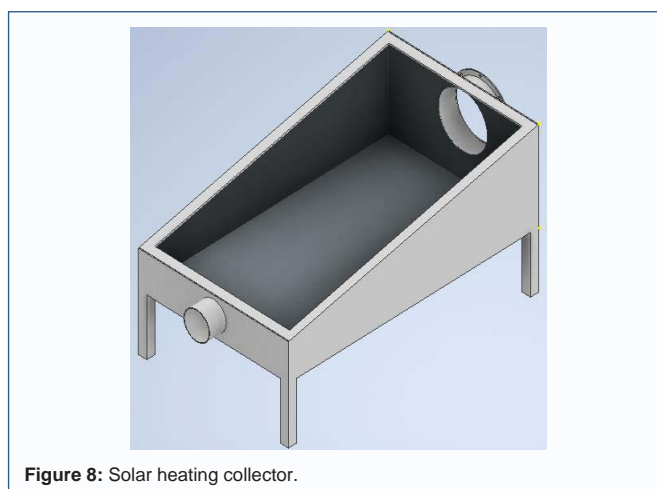

Figure 8: Solar heating collector.

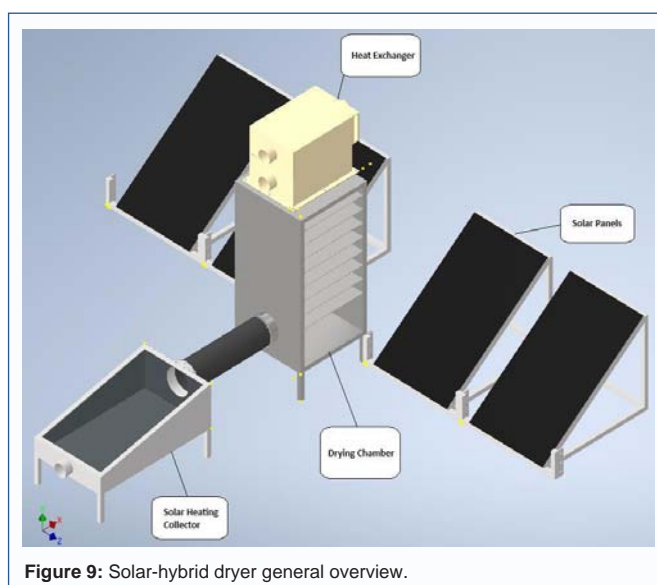

Figure 9: Solar-hybrid dryer general overview.

give the project sponsor a visual of the design. To issue drawings for construction, further detailed modelling and drawings will have to be generated by a professional drafter. The modelling and drawings for the design can be seen below (Figure 7-9).

Electrical design

The electrical system has been designed to have a simple use

Risk Assessment - Manufacturing and Maintenance Process						
Risk ID	Risk	Likelihood	Consequence	Risk Rating	Controls	Accountable
CF1	Laser Cutting (Arc Flash, Hot Surfaces, Sharp Edges)	3	2	Medium 6	Ensure appropriate safety equipment is worn including, eye protection, gloves and apron.	Project Manager, Safety Officer and Operator
CF2	Folding (Pinchpoints)	2	5	High 10	While folding do not place limbs or body parts anywhere near moving parts.	Project Manager, Safety Officer and Operator
CF3	TIG Welding (Arc Flash, Weld Burn, Fire Hazard)	3	2	Medium 6	Ensure appropriate safety equipment is worn including welding mask and gloves, apron, steel capped boots and long pants.	Project Manager, Safety Officer and Welder
CF4	Electrical (Electricution, Fire Hazard)	2	4	Medium 8	Ensure terminals are appropriately connected and remove oxidation where possible while disconnected from power.	Project Manager, Safety Officer and Operator
CF5	Manual Handling (e.g. Spine, Joints, Muscles and Ligaments)	2	3	Medium 6	Ensure appropriate lift techniques are utilised and where possible use two lift points.	Project Manager, Safety Officer and Operator

Table 1: Risk assessment matrix.

interface with simple electronic components that are easy to source and replace. The system has been designed to limit the number of sensors required and avoid complex logic-controlled systems that require specialist equipment and knowledge to maintain.

The system will have a Damper to control the drying chamber air temperature by directing air either through the heat exchanger for heat to be recovered or expelled to prevent heat being recovered as per Figure 5. The damper will be controlled by a proportionally controlled actuator where 0v control is directing all air through the heat exchanger and 12v control is expelling all air to the atmosphere. The damper control will be based on the temperature of the incoming air prior to the heating element. The heating element will be controlled by the set temperature, it will turn on when the air temperature intake falls below the set temperature and will also have a bypass switch to disable the heating element all together, a LED indicator will indicate when the heat element is in use. The heating element, air movement system and control system will be fused separately, the fan and actuator and heating element will be powered via separate relays. It can incorporate IoT for continuous operation with sensors to detect different environmental parameters. Control circuits were developed and modeled using CircuitLab circuit simulator.

Risk Assessment

Risk management was a critical project component, addressing potential personal safety, financial, and environmental concerns. To mitigate potential issues effectively, a formal risk assessment was conducted, alongside the creation of a risk register and regular risk reviews.

Once the final design was selected, detailed design calculations were completed, and a quantity of bills will be prepared to outline the materials and costs involved. The design emphasizes a sustainable approach, integrating renewable energy sources and materials suitable for local availability and conditions.

The following risk assessment (Table 1) is an addition to the project risk assessment and focuses primarily on the manufacturing and maintenance process. Initially the project risk assessment did not specifically cover any risk associated with manufacturing and maintenance due to the lack of finer details. With now a detailed bill of materials and drawings to support construction it is necessary to cover the risk associated with the manufacturing process suggested [21].

Discussion

Design Objectives, Constraints and Assumptions evaluate the total financial outlay for designing, constructing, and implementing the banana powder batch drying system, including capital investment, operational expenses, and maintenance costs. A cost-effective design minimizes expenses while ensuring high-quality output, keeping the project financially viable and accessible for farmers, and contributing to economic stability and income diversification in South Pacific agricultural sector. Energy Supply assesses the availability, reliability, and cost of energy sources needed to operate the drying system, emphasizing potential energy independence. Given South Pacific's climate, the feasibility of using renewable energy, such as solar power, is crucial for sustainability. An energy efficient design reduces reliance on non-renewable energy, lowers costs, and mitigates environmental impact. Ease of Operation and Maintenance (O&M) considers the complexity of operating and maintaining the system and its potential to empower local communities. A user-friendly design with straightforward operation and minimal maintenance needs ensures farmers can manage the system without extensive training, reducing downtime and extending its lifespan, fostering resilience and self-sufficiency. Portability of the system's mobility allows flexible deployment across different locations, enhancing utility, reducing transportation costs, and minimizing post-harvest losses. Portability is particularly beneficial in remote areas, ensuring broader access to technology. Availability assesses the accessibility and procurement

of necessary materials, components, and technologies for the drying system. Ensuring these elements are readily available within South Pacific or can be easily imported is critical for feasibility. High resource availability supports timely implementation, reduces dependency on external suppliers, and ensures continuous operation and maintenance. Sustainability evaluates the environmental impact and contribution to long-term ecological balance. A sustainable design minimises waste, reduces energy consumption, and uses eco-friendly materials and processes. Emphasising sustainability aligns with global climate efforts and promotes responsible agricultural practices, enhancing the resilience of South Pacific's agricultural sector and ensuring positive environmental and community impact. Batch size is crucial in banana powder drying systems. Larger batches enhance equipment efficiency, reduce loading/unloading frequency, and lower production costs per unit. However, they require significant initial investments and may prolong drying times if not well designed. Smaller batches offer flexibility and quicker cycles, which suit variable supply and demand scenarios. In South Pacific's climate, achieving optimal economic and operational efficiency involves balancing these factors. Drying time is pivotal in banana drying system efficiency and design. It directly impacts throughput and product quality. Shorter drying times increase capacity and profitability but require higher energy input and advanced technology, raising operational costs. Longer drying times reduce energy consumption but lower production capacity and might affect product quality. Optimising drying time is crucial in South Pacific's humid climate to prevent spoilage and ensure efficient moisture removal. The equipment and process reliability are paramount when developing a banana drying system. Ensuring consistent performance minimises downtime and maximises output, which is critical for economic stability and sustainable agricultural practices. Reliable systems function dependably under various conditions and require less maintenance, reducing costs and enhancing productivity. Efficient drying systems should convert the maximum number of raw bananas into high-quality banana powder with minimal loss during processing. This involves optimising the drying process to preserve the powder's nutritional and sensory qualities while managing waste and byproducts effectively. Farmers can enhance their income by reducing wastage, contributing to economic stability and resilience.

Conclusion

Manuscript proposes a promising solution in south pacific region: transforming these surplus bananas into powder with an extended life. This initiative aims to leverage solar-powered drying technology, capitalizing on Fiji's abundant sunshine to efficiently and sustainably process bananas. Solar-powered dryers are a fitting solution for the region's climatic conditions, as they offer an eco-friendly method to remove moisture from bananas, thereby preserving their nutritional value and preventing spoilage. By implementing effective drying techniques, this not only seeks to create new income streams for farmers but also plays a crucial role in ensuring food security. The production of banana powder facilitates market expansion and introduces opportunities for value-added products, thus encouraging entrepreneurship within local communities. Beyond economic benefits, this initiative empowers the local community by providing farmers with the tools and knowledge to preserve their produce. It fosters a sense of resilience and self-reliance as farmers gain access to stable, long-term methods of production that are less vulnerable to environmental factors. Through this approach, we aim to strengthen the fabric of Fijian society by promoting sustainable agricultural

practices, reducing food waste, and enhancing the livelihoods of those involved in the banana supply chain. Risk Assessment The following risk assessment is an addition to the project risk assessment and focuses primarily on the manufacturing and maintenance process. This phased approach enhances the product's success and ensures alignment with the community's needs and expectations in the south pacific.

References

1. PayLab. Salaries in the category: Agriculture, Food Industry. 2024.
2. Australian Government Department of Agriculture, Fisheries and Forestry. Codex - International Food Standards. 2023.
3. Alfiya P, Amulya P, Delfiya DA, Murali S, Samuel M. Design and performance evaluation of solar - LPG hybrid dryer for drying of shrimps. *Renewable Energy*. 2020; 147: 2417-2428.
4. Alimardani R, Firouz M, Omid, M. Some physical properties of full-ripe banana fruit (Cavendish variety). *Int J Agricultural Sci Res Technol*. 2011.
5. Atojunere EE, Senadeera W, Iji P, Jimaima L. Development of an indirect active solar heating dryer(IASHD) for dwarf cavendish banana. *Indian J Engineering*. 2025; 23(59): 1-10.
6. Chavan A, Mujumdar A, Thorat B, Vitankar V. Natural convection and direct type (NCDDT) solar dryers: a review. *Drying Technology*. 202; 39(13): 1-22.
7. Climatic Research Unit month-by-month variation in climate. 2020.
8. Prasad RD, Raturi A. Role of Solar Photovoltaics in Future Electricity Generation in Fiji. *Asia Pacific Solar Research Conference*. 2018.
9. Beach Weather. Annual average weather for Fiji. 2024.
10. Energypedia. Fiji Energy Situation, Energypedia, Wiesbaden, Germany. 2018.
11. Amankwah EA, Dzisi KAE, Fofie PA, Marmah AJB, van Boxtel. Drying Characteristics of Dried Banana (*Musa sapientum*). *Journal on Agricultural Engineering*. 2014.
12. Kunwisawa J, Prachayawarakorn S, Soponronnarit S Thuwapanichayanan R. Determination of effective moisture diffusivity and assessment of quality attributes of banana slices during drying. *LWT- Food Science and Technology*. 2011; 44 (6): 1502-1510.
13. Mawire A, Mothupi M, Ramokali M, Vanierschot M. An experimental evaluation of drying banana slices using a novel indirect solar dryer under variable conditions *Heliyon*. 2024; 10(7): 28268.
14. Fernandes L, Tavares P. A Review on Solar Drying Devices: Heat Transfer, Air Movement, and Type of Chambers. *Solar*. 2024; 4(1): 15-41.
15. Piedmont Plastics. Is Polycarbonate Better Than Glass? 2021.
16. Peter Jones. Pros and Cons of Exterior Plywood Cladding. FA Mitchell & Co. 2020.
17. Aaclo. Stainless Steel in Coastal Environments. 2019.
18. Foster S, Macdonald B. Economy of Fiji. *Britannica*. 2024.
19. Atojunere EE, Senadeera W. Enhancing drying conditions of Dwarf Cavendish and Fijian Vudi bananas in an Indirect Active Solar Heating Dryer (IASHD) through insulators Installation *Food Research*. 2026.
20. Chijioke O, Chukwunonye C, Nnaemeka N, Obiora C. Thin Layer Drying Modelling for Some Selected Nigerian Produce: A Review. *Am J Food Sci Nutr Res*. 2016; 3(1): 1-15.
21. SafetyDocs. Hazard Identification and Risk Assessment: Ways of Keeping a Safety Culture. 2024.